

# Berneer<sup>®</sup>

## 2.5" Vandal-proof Dome Camera (Shape B2)

### Features

- Vandal-proof Camera
- SONY/SHARP CCD is optional
- Horizontal resolution 540/480/450/420 TV Lines
- Built in 3.5-8mm varifocal manual iris lens
- Day/night with IR filter or color optional
- Auto Electronic Shutter and auto gain control



### Models

BN-033Q/SS-B2	540 TV lines, 1/3" Sony Super HAD CCD, 0.1Lux, SONY DSP
BN-033Q/SN-B2	540 TV lines, 1/3" Sony Super HAD CCD, 0.1Lux, NEXTCHIP DSP
BN-033H/SS-B2	480 TV lines, 1/3" Sony Super HAD CCD, 0.1Lux, SONY 2613 DSP
BN-033H/SN-B2	480 TV lines, 1/3" Sony Super HAD CCD, 0.1Lux, NEXTCHIP DSP
BN-033D/EN-B2	420 TV lines, 1/3" Sony Ex-view CCD, 0.01Lux, NEXTCHIP DSP
BN-033D/SS-B2	420 TV lines, 1/3" Sony Super HAD CCD, 0.1 Lux
BN-043D/SS-B2	420 TV lines, 1/4" Sony Super HAD CCD, 0.5 Lux
BN-033D/HH-B2	420 TV lines, 1/3" Sharp CCD, 0.5 Lux
BN-043D/HH-B2	420 TV lines, 1/4" Sharp CCD, 0.5 Lux

### Specifications



Horizontal Resolution	540/480/450/420 TV Lines available
Electronic Shutter	PAL=1/50 -1/100,000 sec, NTSC=1/60 -1/100,000 sec
Pixel	540/480 TV lines PAL: 752×582,NTSC: 768×494(H×V)
	450/420 TV lines PAL: 500×582,NTSC: 510×492(H×V)
Lens	3.5-8mm varifocal manual iris lens
Power Supply	DC12V
Power Consumption	65~148mA
Dimension	108×78mm(Φ×H)

Net Weight	0.45kg
Operating Temperature	-10 ~ 50°C (Relative Humidity: 95% max.)

## Dimension

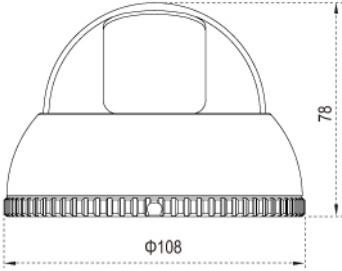
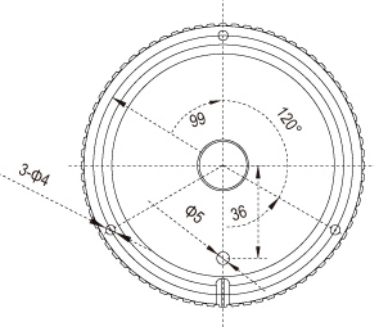
Back View	Side View
	

## Optional Items

BN-B160-1 Bracket	Snapshot
	