

# Indoor & Outdoor Decoder's manual

## BN-800F

## BN-800G



BN-800F



BN-800G

## Berneer production

---

## 1. Equipment Profile:

As a kind of front-end equipment, decoder is used to control pan/tilt, lens, power supply, wiper and light. Keyboard controller, matrix or PC system can use decoder to manage pan/tilt, lens as well as assistant functions. Besides, the decoder is designed for anti-lightning and anti-interference circuit.

## 2. Features:

- Adopt anti-interfering PIC single-chip, CPU builds-in watchdog circuit with photoelectronic isolation.
- Adopt anti-high voltage, anti-static and anti-lightning design, adding communication jamming auto reset skill.
- This decoder offers AC220V, AC24V, DC12V such-and-such three groups of power supplies for devices like camera.
- Pan/tilt voltage can be AC220V or AC24V (AC24V initiated)
- Lens voltage ranges from DV6V to DC12V adjustable (8V initiated), applying for lens speed adjustment.
- Two groups assistant switchers control light, wiper or camera power supply.
- Support selections among multi control protocols and multi communication baud rates, 0-63 addresses setting.

## 3. Specifications:

Models	BN-800F (Indoor)	BN-800G (Outdoor)
Power Supply	AC220V±10%, 50Hz±10%, 30W	AC220V±10%, 50Hz±10%, 50W
Address Code Range	0~63	0~63
Pan/tilt Operation Voltage	AC220V/2A or AC24V/0.8A	AC220V/2A or AC24V/0.8A
Lens Voltage	DC6V~DC12V,600mA	DC6V~DC12V,600mA
Power Output (DC)	DC 12V, 600mA	DC 12V,800mA
Power Supply Output (AC)	AC 24V, 500mA	AC 24V,500mA
Communication Protocols	RS-485, 1200/2400/4800/9600Bit/s Pelco-D, Pelco-P etc	RS-485, 1200/2400/4800/9600Bit/s Pelco-D, Pelco-P etc
Pan/tilt Control	Up/Down/Left/Right/Auto	Up/Down/Left/Right/Auto
Lens Control	Iris/Zoom/Focus	Iris/Zoom/Focus
Assistant Control	2 Relay(AC220V/5A)	2 Relay(AC220V/5A)
Operating Environments	Indoor	Outdoor

Dimension	246×146×57mm	281×176×70mm
Operating Temperature	-40°C~70°C	-40°C~85°C
Weight	1.52kg	2.35kg

#### 4. Pan/tilt Setting:

Can control pan/tilt action of Up/Down/Left/Right/Auto. Pant/tilt voltage can be AC220V or AC24V (precaution: excessive voltage will burn pan/tilt).

#### 5. Lens Setting:







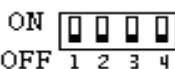

Can control lens iris, focus as well as zoom. Lens voltage is adjusted by potentiometer of circuit, ranges from DC6V to DC12V. The higher the voltage is, the faster the lens speed is.

#### 6. Auxiliary Control:

AUX1 and AUX2 is normal-open switcher, used for controlling light and wiper.

#### 7. Protocol Setting:

4-digit dialup switcher (ON=1, OFF=0) 

Protocol	ID	Dialup Switcher
	1234	
PELCO-D	0000	ON  OFF 1 2 3 4
HY	0001	ON  OFF 1 2 3 4
VICON:Surveyor99	0010	ON  OFF 1 2 3 4
KALATEL(KDT-312)DCW0601	0011	ON  OFF 1 2 3 4
PELCO-P	0100	ON  OFF 1 2 3 4
HN-C	0101	ON  OFF 1 2 3 4
SAMSUNG	0110	ON  OFF 1 2 3 4
KODICOM-RX KRE-301RX	0111	ON  OFF 1 2 3 4

NEOCAM	1001	ON <input type="checkbox"/> <input type="checkbox"/> <input type="checkbox"/> <input type="checkbox"/> OFF 1 2 3 4
PIH1016	1010	ON <input type="checkbox"/> <input type="checkbox"/> <input type="checkbox"/> <input type="checkbox"/> OFF 1 2 3 4
B01	1011	ON <input type="checkbox"/> <input type="checkbox"/> <input type="checkbox"/> <input type="checkbox"/> OFF 1 2 3 4
RM110/S1601	1100	ON <input type="checkbox"/> <input type="checkbox"/> <input type="checkbox"/> <input type="checkbox"/> OFF 1 2 3 4
SANTACHI-450/9600	1111	ON <input type="checkbox"/> <input type="checkbox"/> <input type="checkbox"/> <input type="checkbox"/> OFF 1 2 3 4

### 8. Baud Rate Setting:

1<sup>st</sup> and 2<sup>nd</sup> digit of 8-digit switcher



Baud Rate	ID	Dialup Switcher Position	Notes
	12		
1200 / 19200	00	ON <input type="checkbox"/> <input type="checkbox"/> OFF 1 2	Auto identify 1200 protocol or 19200 protocol
2400	01	ON <input type="checkbox"/> <input type="checkbox"/> OFF 1 2	
4800	10	ON <input type="checkbox"/> <input type="checkbox"/> OFF 1 2	
9600	11	ON <input type="checkbox"/> <input type="checkbox"/> OFF 1 2	

### 9. Address Code Setting:

3<sup>rd</sup> to 8<sup>th</sup> digits of 8-digit switcher (ON=1,OFF=0)

Number	ID	Number	ID
	345678		345678
0	000000	32	100000
1	000001	33	100001
2	000010	34	100010
3	000011	35	100011
4	000100	36	100100
5	000101	37	100101
6	000110	38	100110
7	000111	39	100111
8	001000	40	101000
9	001001	41	101001

10	001010	42	101010
11	001101	43	101011
12	001100	44	101100
13	001101	45	101101
14	001110	46	101110
15	001111	47	101111
16	010000	48	110000
17	010101	49	110001
18	010110	50	110010
19	010011	51	110011
20	010100	52	110100
21	010101	53	110101
22	010110	54	110110
23	010111	55	110111
24	011000	56	111000
25	011001	57	111001
26	011010	58	111010
27	011011	59	111011
28	011100	60	111100
29	011101	61	111101
30	011110	62	111110
31	011111	63	111111

- (1) Dialup switcher: ON=1; OFF=0.
- (2) Address encoding is based on binary system.
- (3) Some hosts addresses initiate as 0, and some initiate from 1.

## 10. Common Faults Analysis & Solutions

Fault Features	Analysis & Solutions
Powered light cannot shine	<ol style="list-style-type: none"> <li>1. Whether supplied voltage is AC220V</li> <li>2. Maybe power switcher shut or fuse burnt</li> </ol>
Out of control	<ol style="list-style-type: none"> <li>2. Whether PC system is normal and whether communication port setting accords with hardware requirement</li> <li>3. Whether address code switcher setting accords with controlled camera address (for NO.1 camera address, some hosts show as 0; but some hosts show as 1)</li> <li>4. Protocol setting incorrect</li> </ol>
Close control available; remote control unavailable	<ol style="list-style-type: none"> <li>1. RS485 converter lacks driving force for output.</li> <li>2. Wiring distance over 1200m should add RS485 repeater or RS485 distributor.</li> </ol>

## 11. Wiring Diagram:

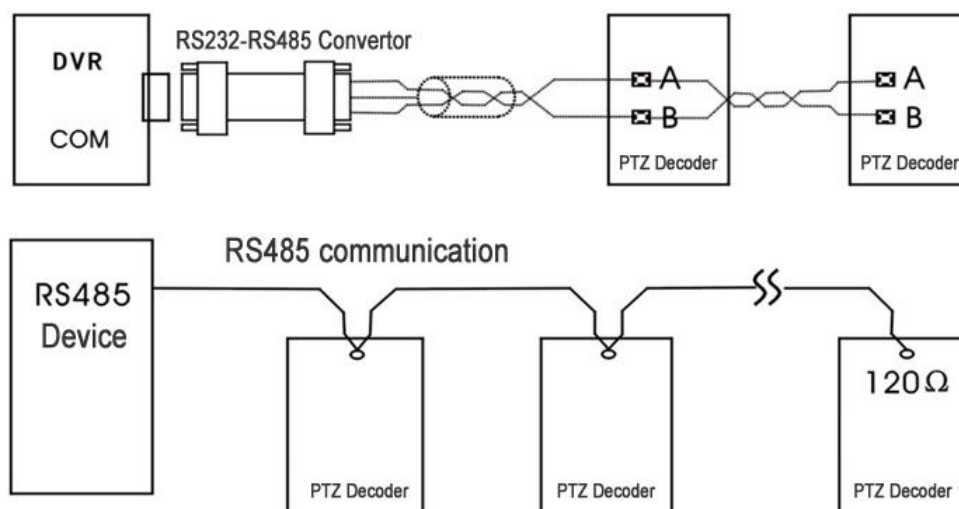

- (1) Control line adopts twisted pair cable which is better than parallel line in transmission distance.
- (2) Decoder adopts dual-core STP (shielded twisted pair) with RS485 communication. Cable length should be within 1200m. Decoder can adopt chain connection or star connection. RS+ (A), RS- (B) is signal end, connecting to A and B port of RS485 host (reverse connection forbidden).
- (3) Multi decoders connection should be finished between the two farthest decoders, moreover adding 120Ω resistor.

## 12. RS485 controlled device use method:

- Wiring method: matrix switcher directly connects to decoder. PC can adopt active or passive RS232-485 converter for connecting with decoder.
- When distance over 1200m or interference excesses, it is necessary to install a RS485 repeater.
- When adopting star wiring, we'd better use RS485HUB which can turn 1 channel RS485 into 4 channels RS485. Thus all channels realize better isolation and less interference between each other, besides effective transmission distance can also be lengthened.
- When interference too serious or adopting non-twisted pair which leads to hard or disable control, we should adopt RS485HUB or RS485 repeater suchlike devices.

## 13. Wiring Diagram:

- RS+ (A) refers to RS485 plus communication; RS-(B) refers to RS485 minus communication.
- DC12V and AC24V refer to the wiring terminal of power supply for camera.
- AUX1 and AUX2 refer to the control switchers of camera power supply, wiper or light.

- AC220V INPUT refers to power supply terminal of decoder, external connecting to AC220V power supply.

**Wiring Diagram:**

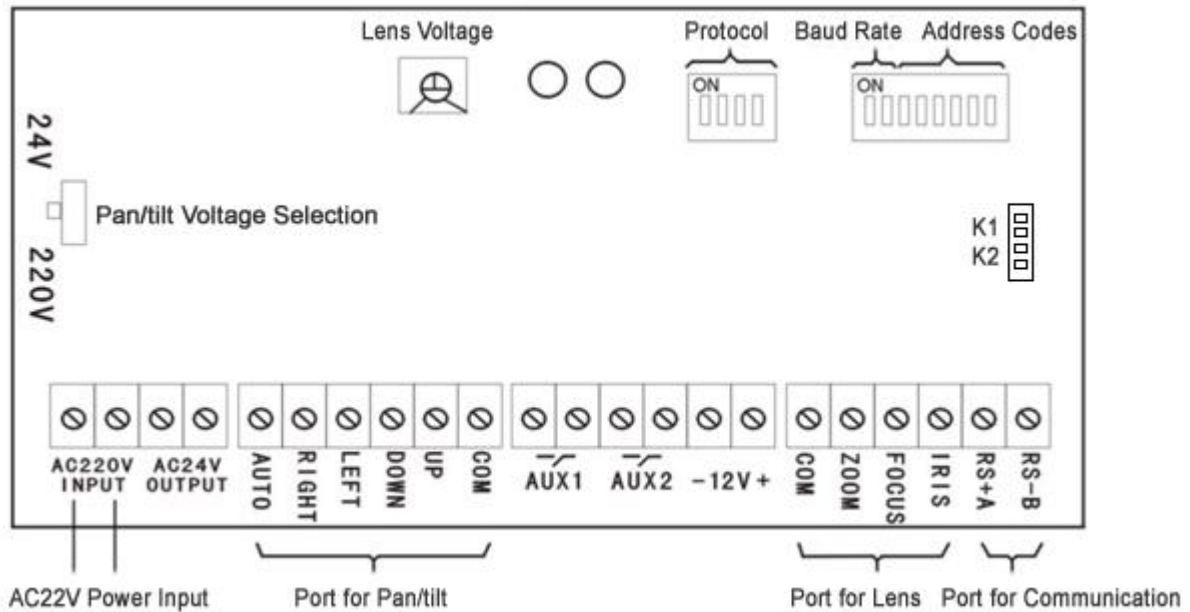

**14. Usage of Decoder Test Function:**

- 1) Switch <K1> terminal of <TEST> module of main board into short-cut state and enter test mode. Then red indicator light shows as flickering.
- 2) In test mode, firstly dial 5<sup>th</sup>-8<sup>th</sup> digits of 8-digit switcher into related function window, then make <K2> terminal short-circuit. Thus test function runs.
- 3) Finishing test, we must cut off <K1> terminal immediately, return to normal operation mode, moreover, dial address code back to original position.

**ID Function Definition of Decoder Test Status (using 5<sup>th</sup>-8<sup>th</sup> digits of 8-digit switcher, ON=1, OFF=0):**

Functions	ID
	5678
Up	0000
Down	0001
Left	0010
Right	0011
Zoom+	0100
Zoom-	0101
Focus+	0110
Focus-	0111

---

Iris+	1000
Iris-	1001
AUX1	1010
AUX2	1011